

## Ixxat Safe T100/CS

The Ixxat Safe T100/CS offers device manufacturers an easy way to control safe I/O signals using a safe fieldbus protocol. The module meets the SIL3 safety requirement level as defined by IEC 61508 and Performance Level PLe / Category 4 in ISO 13849-1.

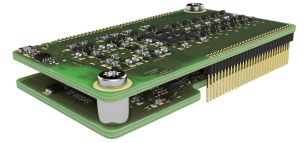

Safe T100/CS is primarily designed to be used together with Anybus CompactCom, where the safety communication uses the black channel principle through Anybus CompactCom. For CIP Safety, CompactCom takes over the EtherNet/IP Adapter functionality and the safety module implements the CIP safety layer and safe control of three dual-channel inputs as well as one dual-channel output.

The module's very compact size and flexible safety I/O routing make it perfect for integration into customer specific device solutions.

### FEATURES AND BENEFITS

- All necessary functions and methods to achieve SIL-3/Performance Level e (PLe) on one board — simplifies customer board design
- IOs configurable for single and dual channel use
- Pre-certified concept and hardware for easy re-certification of the final device
- Provision of full documentation set including TÜV type approval
- Direct connectivity to Anybus CompactCom module for non-safe fieldbus communication - safe and non-safe communication on the same wire

### TECHNICAL SPECIFICATIONS

<b>Supported standards</b>	CIP Safety (Volume 5, V2.19)
<b>Digital inputs</b>	3 x dual channel, configurable with filter and monitor functions
<b>Digital outputs</b>	1 x dual channel, configurable
<b>Safety Conformance Level</b>	max. SIL 3, Performance Level e (PLe) category 4
<b>Power supply</b>	24 V DC (SELV/PELV), 3.3 V DC
<b>Operating temperature</b>	-30 °C to +68 °C
<b>Dimensions</b>	70 x 40 x 15 mm

### HOW IT WORKS

#### BLACK CHANNEL PRINCIPLE

The Ixxat Safe T100 is used in customer devices together with a communication module of the **Anybus CompactCom** series, which is used to implement the unsafe bus connection. Safety communications use the black channel principle through the Anybus CompactCom communication module. For CIP Safety, for example, the communication module carries out the tasks of an EtherNet/IP Adapter.

### Black channel principle:

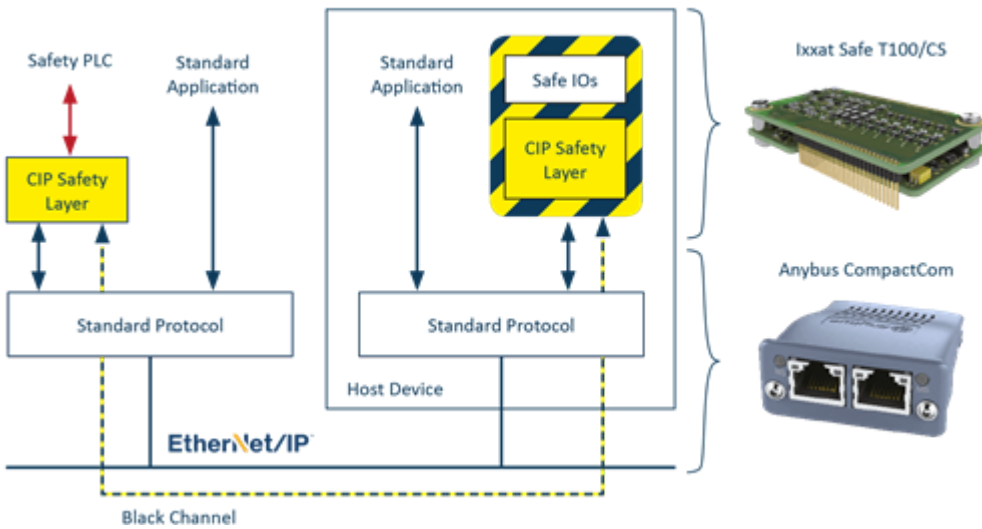

### Application sample:

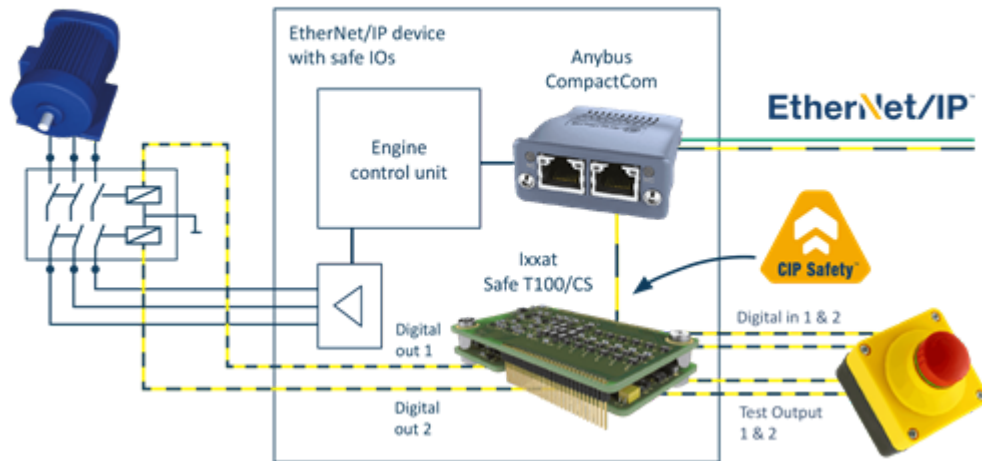

### EASY CERTIFICATION



A comprehensive safety manual is provided for device certification. This describes all the needed integration and verification steps to achieve the TÜV certification which greatly reduces the time-to-market. Especially the clear separation of safety-relevant functions from the unsafe functions of the end device by the precertified Ixxat Safe T100 plug board is a great help in this situation.

### DEVELOPMENT KIT

The Safe T100 comes with development kits for evaluation purposes. These consist of a base board with a EtherNet/IP Anybus CompactCom module and a host CPU, along with the suitable safety module with easy to access safety I/O signals. The configuration of the Safety I/Os is done via the fieldbus connection.



## Ordering information

Order code	Description
1.01.0301.00002	Ixxat Safe T100/CS
025800-B	T100 Development Kit for Ixxat Safe T100/CS

---

Copyright © 2020 HMS Industrial Networks - All rights reserved.